

# MIS2ION™

Owner's Manual







Users can view the electronic instructions at <https://www.kress.com/en/>.

# Product safety

## General safety warnings



**WARNING: Read all safety warnings and all instructions.** Failure to follow the warnings and instructions may result in electric shock, fire and/or serious injury.

**Carefully read the instructions for the safe operation of the machine.**

**Save all warnings and instructions for future reference.**

- This appliance is not intended for use by persons (including children) with reduced physical, sensory or mental capabilities, or lack of experience and knowledge, unless they have been given supervision or instruction concerning use of the appliance by a person responsible for their safety.
- Children should be supervised to ensure that they do not play with the appliance.
- This appliance contains batteries that are only replaceable by skilled persons.

WARNING: For the purposes of recharging the battery, only use the detachable supply unit provided with this appliance.

## Do not expose the appliance or battery to excessive temperatures:

1. rechargeable batteries are to be removed from the appliance before being charge;
2. different types of batteries or new and used batteries are not to be mixed;
3. exhausted batteries are to be removed from the appliance and safely disposed of;
4. if the appliance is to be stored unused for a long period, the batteries should be removed;
5. do not use non-rechargeable batteries in place of rechargeable batteries;
6. do not use modified or damaged batteries;
7. WARNING: Use only with KA0200 battery charger or additional battery chargers listed in Operator's Manual.

**IMPORTANT  
READ CAREFULLY BEFORE USE  
KEEP FOR FUTURE REFERENCE**

## Safe operation practices Training

- a) Read the instructions carefully. Make sure you understand the instructions and be familiar

with the controls and the proper use of the appliance.

- b) Never allow people unfamiliar with these instructions or children to use the appliance. Local regulations can restrict the age of the operator.
- c) The operator or user is responsible for accidents or hazards occurring to other people or their property.

## Preparation

- a) Confirm that the virtual boundary is established as instructed and the virtual boundary is regularly maintained. Before each working cycle, the machine goes around the working area to check whether the virtual boundary exists, if it does not exist, the machine will shut down. The virtual boundary specifies the work area where the machine is allowed to operate. The RTK antenna in the machine senses when it is approaching the virtual boundary. When the machine hits an obstacle or approaches the virtual boundary the product selects a new direction.
- b) Periodically inspect the area where the appliance is to be used and remove all stones, sticks, wires, bones, and other foreign objects.
- c) Periodically visually inspect to see that the blades, blade bolts and cutter assembly are not worn or damaged. Replace worn or damaged blades and bolts in sets to preserve balance.
- d) On multi-spindle appliances, take care as rotating one blade can cause other blades to rotate.
- e) WARNING! The lawnmower shall not be operated without the guard in place.

## Operation

### 1. General

- a) Never operate the appliance with defective guards, or without safety devices, for example deflectors, in place.
- b) Do not put hands or feet near or under rotating parts. Keep clear of the discharge opening at all times.
- c) Never pick up or carry an appliance while the motor is running.
- d) Operate the disabling device from the appliance
  - Before clearing a blockage;
  - Before checking, cleaning or working on the appliance;
  - After striking a foreign object to inspect the machine for damage;

- If the machine starts to vibrate abnormally, and to check for damage before restarting.
- e) It is not permitted to modify the original design of robotic lawnmower. All modifications are made at your own risk.
- f) Start robotic lawnmower according to the instructions. When the power is on, make sure you keep your hands and feet away from the rotating blades. Never put your hands and feet under the mower.
- g) Never lift up robotic lawnmower or carry it when the power is on.
- h) Do not let persons who do not know how robotic lawnmower works and behaves use the mower.
- i) Do not put anything on top of robotic lawnmower or its charging base.
- j) Do not allow robotic lawnmower to be used with a defective blade disc or body. Neither should it be used with defective blades, screws, nuts or cables.
- k) Always switch off robotic lawnmower when you do not intend to use the mower. Robotic lawnmower can only start when the power is on and the correct PIN code has been entered.
- l) Keep your hands and feet away from the rotating blades. Never place your hands or feet close to or under the body when robotic lawnmower is in operation.
- m) To avoid using the machine and its peripherals in bad weather conditions especially when there is a risk of lightning.
- n) Not to touch moving hazardous parts before these have come to a complete stop.
- o) For machines used in public areas, that warning signs shall be placed around the working area of the machine. They shall show the substance of the following text:  
Warning! Automatic lawnmower! Keep away from the machine! Supervise children!

## 2. Additionally when the appliance is operating automatically

- a) Do not leave the machine to operate unattended if you know that there are pets, children or people in the vicinity.
- b) Please set the smart phone to automatically lock the screen after 30 s to prevent the app from being misused by others.

### Maintenance and storage



**WARNING! When the mower is turned upside down the power must always be off.**

**The power should be off during all work on**

### the mower's underframe, such as cleaning or replacing the blades.

- a) Keep all nuts, bolts and screws tight to be sure the appliance is in safe working condition.
- b) Inspect the robotic lawnmower each week and replace worn or damaged parts for safety.
- c) Check especially that the blades and blade disc are not damaged. Replace all blades and screws at the same time if necessary so that the rotating parts are balanced.
- d) Ensure that only replacement cutting means of the right type are used.
- e) Ensure that batteries are charged using the correct charger recommended by the manufacturer. Incorrect use may result in electric shock, overheating or leakage of corrosive liquid from the battery.
- f) In the event of leakage of electrolyte flush with water/neutralizing agent, seek medical help if it comes into contact with the eyes etc.
- g) Servicing of the appliance should be according to manufacturers' instructions.

### Recommendation

To connect the machine and/or its peripherals only to a supply circuit protected by a residual current device (RCD) with a tripping current of not more than 30 mA.

### Residual risks

To avoid injuries, wear protective gloves when replacing the blades.

### Transport

The original packaging should be used when transporting robotic lawnmower over long distances.

To safely move form or within the working area:

- a) Press the STOP button to stop the mower.  
You select the four digit PIN code when you start the mower for the first time.
- b) Always switch off robotic lawnmower if you intend to carry the mower.
- c) Carry the mower by the handle at the rear under the mower. Carry the mower with the blade disc away from the body.

### RF exposure requirements

To satisfy RF exposure requirements, a separation distance of 200mm or more should be maintained between this device and persons during device operation.

To ensure compliance, operations at closer than

this distance is not recommended. The antenna used for this transmitter must not be co-located in conjunction with any other antenna or transmitter.

This is a class III appliances and it must only be supplied at safety extra low voltage corresponding to the marking on the appliance.

### **Safety Warnings for battery pack inside the tool**

- a) **Do not dismantle, open or shred battery pack.**
- b) **Do not short-circuit a battery pack. Do not store battery packs haphazardly in a box or drawer where they may short-circuit each other or be short-circuited by conductive materials.** When battery pack is not in use, keep it away from other metal objects, like paper clips, coins, keys, nails, screws or other small metal objects, that can make a connection from one terminal to another. Shorting the battery terminals together may cause burns or a fire.
- c) **Do not expose battery pack to heat or fire. Avoid storage in direct sunlight.**
- d) **Do not subject battery pack to mechanical shock.**
- e) **In the event of battery leaking, do not allow the liquid to come into contact with the skin or eyes. If contact has been made, wash the affected area with copious amounts of water and seek medical advice.**
- f) **Keep battery pack clean and dry.**
- g) **Recharge only with the charger specified by Kress. Do not use any charger other than that specifically provided for use with the equipment.**
- h) **Do not use any battery pack which is not designed for use with the equipment.**
- i) **Keep battery pack out of the reach of children.**
- j) **Retain the original product literature for future reference.**
- k) **Dispose of properly.**
- l) **Do not mix cells of different manufacture, capacity, size or type within a device.**
- m) **Keep the battery away from microwaves and high pressure.**
- n) **Warning! Do not use non-rechargeable batteries.**

### **User manual requirements for wireless product**

- a) Operation of this device is subject to the

following two conditions:

(1) This device may not cause harmful interference, and

(2) this device must accept any interference received, including interference that may cause undesired operation.

- b) **Caution:** Changes or modifications to this unit not expressly approved by the party responsible for compliance could void the user's authority to operate the equipment.
- c) **NOTE:** This equipment generates, uses and can radiate radio frequency energy and, if not installed and used in accordance with the instructions, may cause harmful interference to radio communications. However, there is no guarantee that interference will not occur in a particular installation. If this equipment does cause harmful interference to radio or television reception, which can be determined by turning the equipment off and on, the user is encouraged to try to correct the interference by one or more of the following measures:
  - Reorient or relocate the receiving antenna.
  - Increase the separation between the equipment and receiver.
  - Connect the equipment into an outlet on a circuit different from that to which the receiver is connected.
  - Consult the dealer or an experienced radio/TV technician for help.

### **For mobile device**

- a) To satisfy EMC & RF exposure requirements, a separation distance of 20 cm or more should be maintained between the antenna of this device and persons during device operation.
- b) To ensure compliance, operations at closer than this distance is not recommended.

# Symbols



WARNING – robotic lawnmower can be dangerous if incorrectly used. Read through the Operator's manual carefully and understand the content before using your robotic lawnmower.



WARNING - Keep a safe distance from the machine when operating.



WARNING – Operate the disabling device before working on or lifting the machine.



WARNING – Do not ride on the machine.



Class III appliance

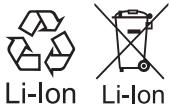

Li-Ion Li-Ion

Li-Ion battery. This product has been marked with a symbol relating to 'separate collection' for all battery packs and battery pack. It will then be recycled or dismantled in order to reduce the impact on the environment. Battery packs can be hazardous for the environment and for human health since they contain hazardous substances.



Do not burn.



Batteries may enter water cycle if disposed improperly, which can be hazardous for ecosystem. Do not dispose of waste batteries as unsorted municipal waste.



Do not wash the machine with a high pressure washer



Read operator's manual



Detachable supply unit



Plus; positive polarity



Minus; negative polarity



RCM marking

ABN: Australian Business Number. By this number, business information such as entity type, status, business location etc. can be found at website <http://abr.business.gov.au>.

ABN of Positec Australia Pty Limited is 14 101 682 357

# Component list

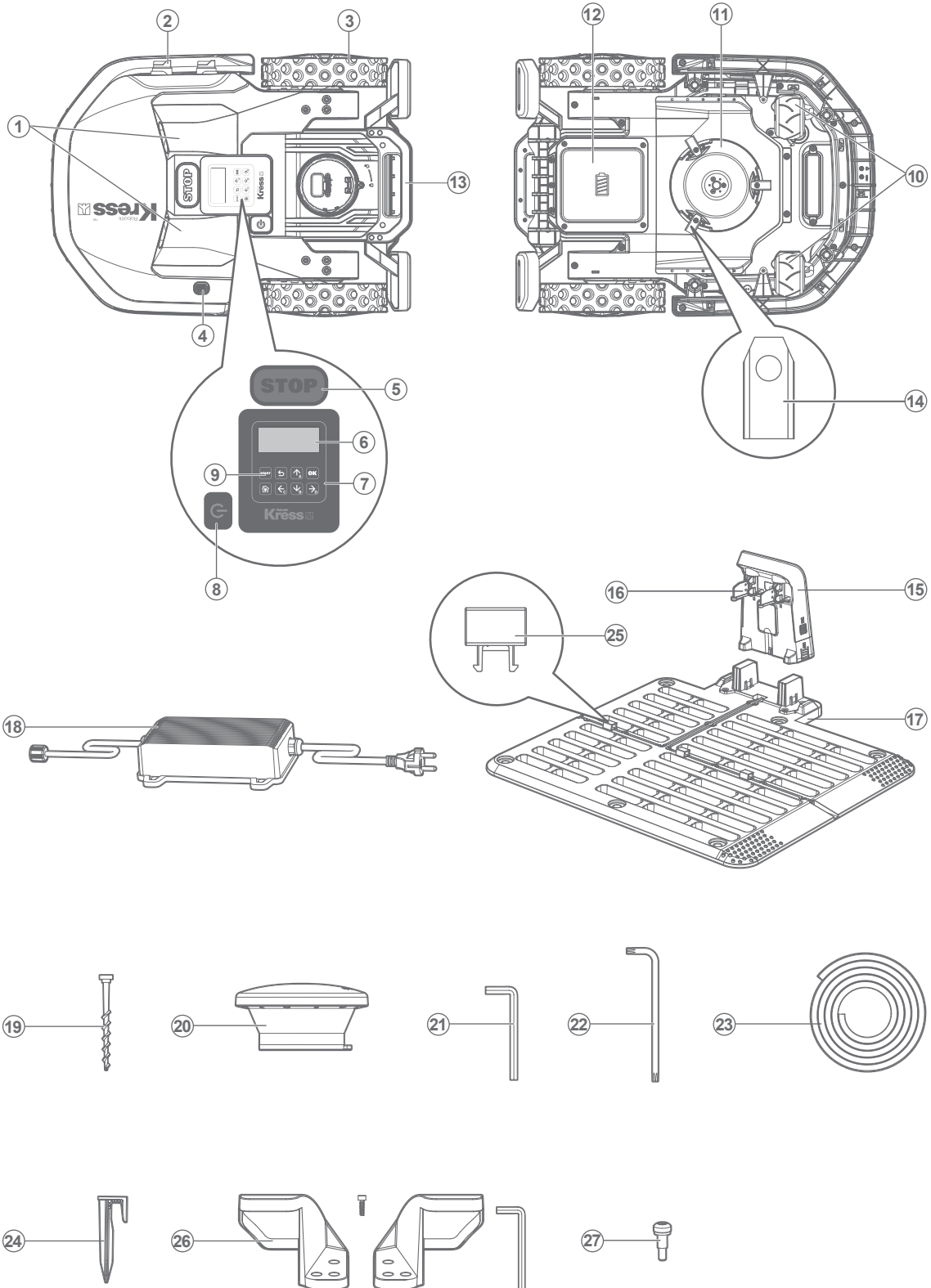

- |                        |                                      |
|------------------------|--------------------------------------|
| 1. Ultrasonic sensor   | 15. Charging Pile                    |
| 2. Charging Strips     | 16. Contact Pins                     |
| 3. Rear Driving Wheel  | 17. Charging Base                    |
| 4. Rain Sensor         | 18. Power Adapter                    |
| 5. STOP Button         | 19. Charging Base Fixing Nails       |
| 6. Display             | 20. RTK Antenna                      |
| 7. Keypad              | 21. Hex Key                          |
| 8. ON/OFF Key          | 22. Wrench for RTK antenna           |
| 9. START Key           | 23. Magnetic Strip                   |
| 10. Front Wheel        | 24. Staples                          |
| 11. Blade Turning Disc | 25. Buckle                           |
| 12. Battery Pack *     | 26. Fender and wrench                |
| 13. Handle             | 27. Anti-theft screw for RTK antenna |
| 14. Cutting Blade      |                                      |

**\*Not all the accessories illustrated or described are included in standard delivery.**

## Technical data

Type **KR161E.1 (100-199 - designation of machinery, representative of Robotic Lawnmower)**

	<b>KR161E.1</b>
Rated voltage	20 V $\equiv$ Max.*
No load speed	2700 /min
Cutting area**	1000 m <sup>2</sup>
Cutting diameter	20 cm
Cutting height	30-60 mm
Cutting height positions	7
Battery type	Lithium-ion
Battery model	KA3024
Charging time approx.	180 min
Charger model	KA0200
Charger rating	Input: 100-240 V~50/60 Hz, 38 W, Output: 20 V, 1.5 A
Machinery weight	12.2 kg
Protection degree	III
APP	Y
Maximum slope within the work surface	40%
The normal temperature range for charging the battery	0 °C~55 °C

\* Voltage measured at no load. Initial battery voltage reaches maximum of 20 volts. Nominal voltage is 18 volts.

\*\* The total cutting area within all the active presets should not be over the recommended area size. The

exceeded area cannot be assigned to the mower.

## Technical Data For Antenna

Rated voltage	5V±2%		
operating temperature	-40°C~85°C		
Storage temperature	-40°C~85°C		
Band	Tx(Mhz)	Rx(Mhz)	RF Output Power (Max)
GSM900(B8)	880-915	925-960	33dBm
DCS1800(B3)	1710-1785	1805-1880	30dBm
WCDMA B1	1920-1980	2110-2170	24dBm
WCDMA B8	880-915	925-960	24dBm
LTE-FDD B1	1920-1980	2110-2170	23dBm
LTE-FDD B3	1710-1785	1805-1880	23dBm
LTE-FDD B7	2500-2570	2620-2690	23dBm
LTE-FDD B8	880-915	925-960	23dBm
LTE-FDD B20	832-862	791-821	23dBm
LTE-FDD B28	703-748	758-803	23dBm
LTE-TDD B38	2570-2620	2570-2620	23dBm
LTE-TDD B40	2300-2400	2300-2400	23dBm

10  
EN

## Technical data for 4G-GPS

4G module -GNSS	GNSS GPS Band L1	1575.42+/-1.023
	Galileo Band E1	1575.42+/-1.023
	BDS Band E11	1561.098+/-2.046
	GLONASS Band G1	1579.5~1605.8

## Noise data

	<b>KR161E.1</b>
A weighted sound pressure	$L_{pA} = 47.5 \text{ dB (A)}, K_{pA} = 3.0 \text{ dB(A)}$

A weighted sound power	$L_{WA} = 55.5 \text{ dB (A)}, K_{WA} = 3.0 \text{ dB(A)}$
Wear ear protection when sound pressure is over	80dB(A) 

A degree of noise from the machine is not avoidable. Route noisy work is to be licensed and limits for certain periods. Keep rest periods and they may need to restrict the working hours to a minimum. For their personal protection and protection of people working nearby, an appropriate hearing protection shall be worn.

## Accessories

	<b>KR161E.1</b>
Screw for fixing blades	9
Charging base	1
Charging base fixing nails	6
Hex key	1
Wrench for RTK antenna	1
Magnetic strip	1
Measurement gauge	2
Blade	9
RTK antenna	1
Staples	16
Fender and wrench	1
Anti-theft screw for RTK antenna	1
Battery pack (KA3024)	1
Charger (KA0200)	1

We recommend that you purchase genuine accessories listed in the above list from the same store that sold you the tool. Refer to the accessory packaging for further details. Store personnel can assist you and offer advice.

## Intended Use

The garden product is intended for domestic lawn mowing. It is designed to mow often, maintaining a healthier and better looking lawn than ever before. Depending on the size of your lawn, Mission™ RTK<sup>n</sup> may be programmed to operate at any time or frequency. It is not intended for digging, sweeping or snow cleaning.

## Maintenance

Your Mission™ RTK<sup>n</sup> works hard and needs to be cleaned and checked from time to time. Some parts will require replacement as they become worn. Never use your Mission™ RTK<sup>n</sup> with defective on/off switch. Switch off the machine before carrying out any service or maintenance. Here's how to take care of your Mission™ RTK<sup>n</sup>.

# 1

## Keep it Sharp



**WARNING:** Before cleaning, adjusting, or replacing the blades, turn your Mission™ RTK<sup>n</sup> OFF and put on protective gloves.



**WARNING:** When fitting new blades, make sure you replace ALL the blades. Always use new screws when fitting blades. This is important to ensure blade retention and balance the blade turning disc. Failure to use new screws could cause serious injury.

The Mission™ RTK<sup>n</sup> does not cut grass like other mowers. Its cutting blades are razor sharp on 2 edges and rotate in both directions for maximum cutting capacity. Redesigned blade profile better prevents grass clippings from getting caught in the gap between the disc and the blade. And with new material, the service life of each cutting blade will be longer than that of other brands' when it is programmed to mow every day. Always check to see if the blades are chipped or damaged and replace them if they are. When the cutting blades are dull and worn out, they should be replaced with the spare blades provided with your Mission™ RTK<sup>n</sup>. Spare blades are also available at your nearest Kress retailer.

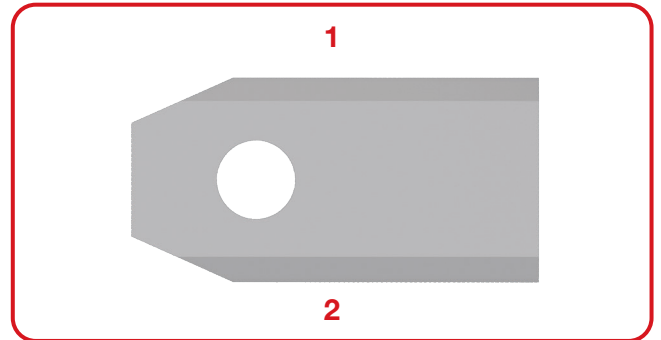

### A. Replace the blades

12

EN

Usually your Mission™ RTK<sup>n</sup>'s blades need to be reversed each month and replaced every week, you can adjust the frequency of replacing the blade according to the cutting quality of the lawn. When replacing the blades, make sure to replace all of them at the same time. You can replace them with one of the spare blade kits and extra blade screws supplied with your Mission™ RTK<sup>n</sup>.

Before attempting to replace your Mission™ RTK<sup>n</sup>'s blades, turn the power off and put on protective gloves and follow these steps:

1. Gently flip the Mission™ RTK<sup>n</sup> over.
2. Remove the battery cover and remove the battery.
3. Take the screws off the blades with a screwdriver.
4. Firmly screw on the new blades.
5. Refit the battery and the battery cover.

**Important:** After screwing the blade to the blade disc, make sure the blade is able to spin freely.

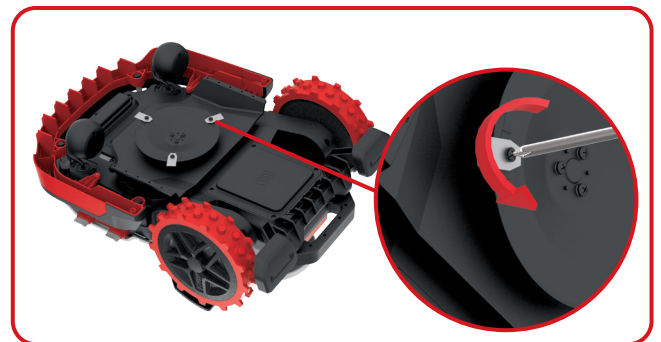

# 2

## Keep it Clean



**WARNING:** Before cleaning, turn your Mission™ RTK<sup>n</sup> OFF. Put on protective gloves before cleaning the blade turning disc and do not rinse or flush with water.



**WARNING!** YOUR Mission™ RTK<sup>n</sup> can only be washed by using a hose! DO NOT use high pressure washer on your Mission™ RTK<sup>n</sup>. High pressure water can go inside the sealings and damage electronic and mechanical parts.

### A. Cleaning the Body

Your Mission™ RTK<sup>n</sup> will live a much happier and longer life if it is cleaned regularly. Since your Mission™ RTK<sup>n</sup> is an electric machine, you will need to take care when cleaning. Hose water clean is supported. It is best to use a spray bottle filled with water. When cleaning the machine body, use a soft brush or clean cloth and avoid using solvents or polishes. Lastly, remove all build up of grass clippings and debris.

### B. Cleaning the underside

Again, it is important that you power the Mission™ RTK<sup>n</sup> OFF and **wear protective gloves before touching the blade turning disc**. First, flip your Mission™ RTK<sup>n</sup> upside down to expose its underside. Here you will see the blade disc, the chassis, and the front wheel and driving wheels. Clean everything thoroughly with a soft brush or moist rag. Hose water clean is supported.

Rotate the blade disc to ensure it rotates freely. Check the blades spin freely around the fixing screws. Remove any obstructions.

**IMPORTANT:** Remove any stuck debris so that it does not cause a crack in the blade disc. Even the tiniest crack can decrease your Mission™ RTK<sup>n</sup>'s mowing output.

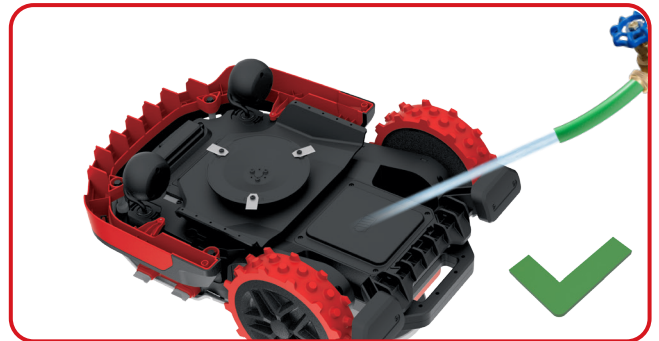

### C. Clean the contact pins and the charging strips

Clean the contact pins located on the charging base and the charging strips located on the Mission™ RTK<sup>n</sup> using a cloth. Remove any built up grass clippings or debris around the contact pins and charge strips periodically to ensure the Mission™ RTK<sup>n</sup> successfully charges each time.

# 3

## Battery Life

The heart of the Mission™ RTK<sup>n</sup> is its 20V Li-Ion Battery. For proper storage of the battery, make sure it is fully charged and kept in a cool dry place between (-20°C~+60°C).

**NOTE:** The recommend Mission™ RTK<sup>n</sup> operation temperature is between 0-55°C.

The life-span of the Mission™ RTK<sup>n</sup>'s battery depends on various factors, such as:

- The length of the mowing season in your region
- Amount of hours the Mission™ RTK<sup>n</sup> mows per day
- Battery maintenance during storage

Mission™ RTK<sup>n</sup> can be charged manually.

1. Connect the charging base to a suitable power supply. The green light on the charging base will turn on.
2. Manually dock the Mission™ RTK<sup>n</sup> into the charging base while the Mission™ RTK<sup>n</sup> is powered off.
3. The green light on the charging base will be flashing and Mission™ RTK<sup>n</sup> will begin to charge.



# 4

## Winter Hibernation

Your Mission™ RTK<sup>n</sup> will live longer and healthier if it is allowed to hibernate. So even though it is tough, we recommend storing your Mission™ RTK<sup>n</sup> in your shed or garage during the winter.

Before you prepare your Mission™ RTK<sup>n</sup> for winter hibernation, we recommend you:

- Thoroughly clean your Mission™ RTK<sup>n</sup>
- Fully charge the battery
- Turn the power off

To maximize the battery life, fully charge the battery before storage during winter.

**!** **WARNING: Protect the underside of Mission™ RTK<sup>n</sup> from water. NEVER store Mission™ RTK<sup>n</sup> upside down outdoors.**

**NOTE:** When bringing the Mission™ RTK<sup>n</sup> back to work after winter hibernation, make sure the charging strips and contact pins are clean. We recommend using a fine grade emery cloth to clean the contacts. Using the app, make sure the date and time are correct and send Mission™ RTK<sup>n</sup> back to what it loves doing: mowing.

# 5

## Replacing the battery

**!** **WARNING: Power off before attempting any adjustment, replacement or repair.**

**Before replacing the blades, turn your Mission™ RTK<sup>n</sup> OFF and put on protective gloves.**

If you need to replace the battery, follow these steps:

1. Gently turn your Mission™ RTK<sup>n</sup> upside down.
2. Remove the screws on the battery cover.  
Remove the battery cover.



3. Remove the screws on the sheet metal.  
Remove the sheet metal.
4. Press the latch and release the connectors as the picture shown. Lift out the battery box carefully.

**NOTE:** Do not pull by the cables. Hold the connectors and release the latch.

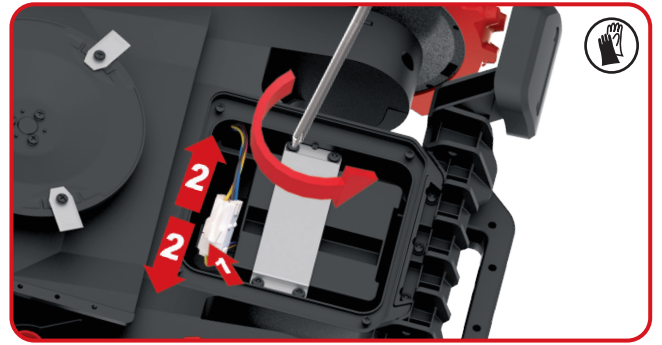

5. Open the battery box then lift out the battery carefully. Replace the old battery with the new one.

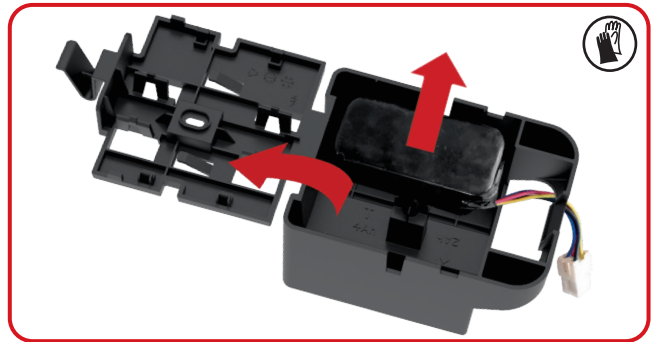

6. Put the battery box back in its position and plug the connectors. Refit the sheet metal.



7. Place the cover back in its position and tighten the screws.

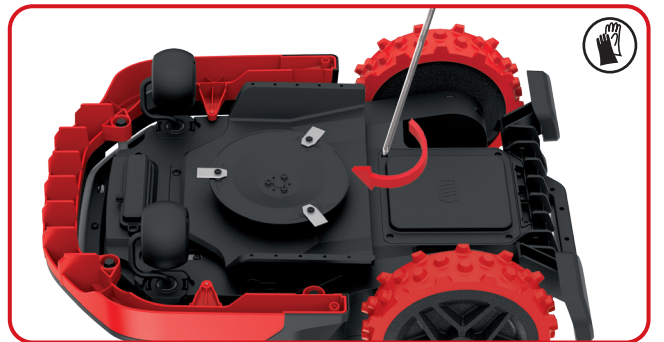

# Troubleshooting

If your Mission™ RTK<sup>n</sup> does not work correctly, follow the trouble shooting guide below. If the fault persists, contact your dealer.

Symptom	Cause	Solution
The LED light on the charging base does not turn on.	There is no power.	Check the charging base is connected properly to the charger and the charger is connected to a suitable power supply.
Mission™ RTK <sup>n</sup> cannot correctly dock with the charging base.	The magnetic strip is placed in the wrong direction.	Check if the magnetic strip is placed in the wrong direction. When correctly placed, the green stripe of the magnetic strip is facing away from the charging base.
Machine runs out of power but does not return to charging base.	No virtual charging base is mapped.	Rebuild the map and add the virtual charging base.
	The length of the magnetic strip is less than 2.5 m.	The length of the magnetic strip should be guaranteed to be greater than 2.5 m.
When Mission™ RTK <sup>n</sup> is going downhill, it overruns the boundary line.	The angle of the border line is very sharp.	Try to avoid layout scenarios with sharp angles.
After Mission™ RTK <sup>n</sup> is turned on, the start button is pressed, but Mission™ RTK <sup>n</sup> does not work.	Mission™ RTK <sup>n</sup> is outside the working area.	Move Mission™ RTK <sup>n</sup> inside the working area.
	Poor positioning signal	Find an open place, wait for the positioning signal light to turn green, and then press start button.
Mission™ RTK <sup>n</sup> does not give an alarm when it is outside the Geo fence.	The software of Mission™ RTK <sup>n</sup> itself is not the latest.	Update the software of the Mission™ RTK <sup>n</sup> .
	Mission™ RTK <sup>n</sup> is powered off.	Turn Mission™ RTK <sup>n</sup> on.
Mission™ RTK <sup>n</sup> is parked in the middle of the obstacle.	The obstacles around Mission™ RTK <sup>n</sup> are relatively small, and Mission™ RTK <sup>n</sup> fails to get out of trouble.	Set the area where Mission™ RTK <sup>n</sup> is easily trapped as No-Go.
	The sensor of Mission™ RTK <sup>n</sup> is abnormal	Detect Mission™ RTK <sup>n</sup> 's diagnostic page on the APP and check the sensor status.
Unable to read log	The format of U-disk is not <b>FAT32</b> .	Convert the format of U-disk to <b>FAT32</b> .
Mission™ RTK <sup>n</sup> is parked around the wall and cannot be started, and the positioning light is always on red.	Mission™ RTK <sup>n</sup> works in the shaded area for too long, triggering the safety protection.	Try to avoid letting Mission™ RTK <sup>n</sup> mow in areas with too much shade.
	There are too many walls or trees in the area, blocking the positioning signal.	

# Environmental protection

 Waste electrical products should not be disposed of with household waste. Please recycle where facilities exist. Check with your Local Authority or retailer for recycling advice.

## For battery tools:

Details regarding safe disposal of used batteries

At the end of the life of the appliance, remove the battery pack safely before disposing of the appliance. Do not throw batteries away or throw them in the normal trash can. Also do not dispose of the battery with the machine. Remove the used battery pack from the appliance and dispose of it at the nearest or convenient dedicated recycling facility. If in doubt, consult your local environmental protection department. Batteries may enter water cycle if disposed improperly, which can be hazardous for ecosystem. Do not dispose of waste batteries as unsorted municipal waste.

Positec Australia Pty Limited  
10 Corporate Blvd Bayswater, VIC 3153, Australia







# MISION™

[www.kress-robotik.com](http://www.kress-robotik.com)