

# Kress

# Commercial



## SAFETY AND OPERATING MANUAL

Cordless Chainsaw

KC300 KC300.X



# TABLE OF CONTENTS

Introduction.....	3
Component List.....	4
Product Safety.....	6
Assembly & Operation.....	12
Transportation .....	17
Saw Maintenance .....	18
Cleaning.....	20
Storage.....	20
Troubleshooting .....	21
Technical Data.....	22

## INTRODUCTION

Dear Customer,

Thank you for buying this Kress Commercial product. We are dedicated to developing high quality products to meet your commercial landscaping requirements.

The Kress brand is synonymous with premium quality service. Over the years of your product's life, if you have any questions or concerns about your product, please contact your dealer or our Customer Service Team for assistance.

We are confident you will enjoy working with your Kress product for years to come.

## INTENDED USE

This Chainsaw is designed for felling trees, limbing, bucking tree trunks, cutting wooden beams, etc. All cuts should be across the grain. This product is intended for cutting wood only.

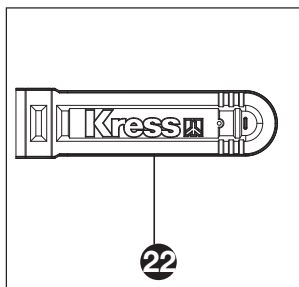
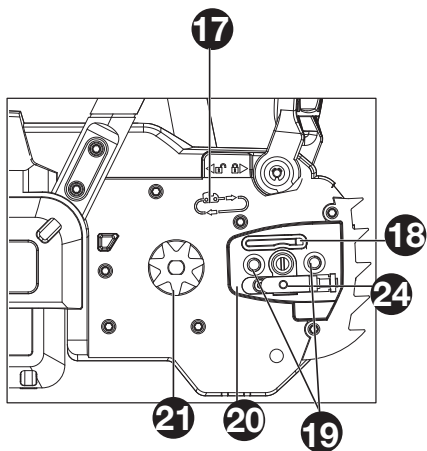
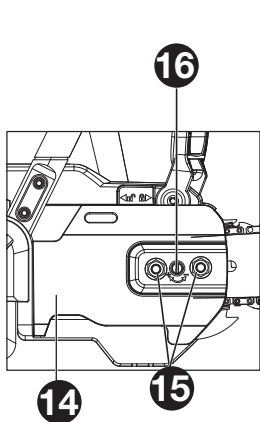
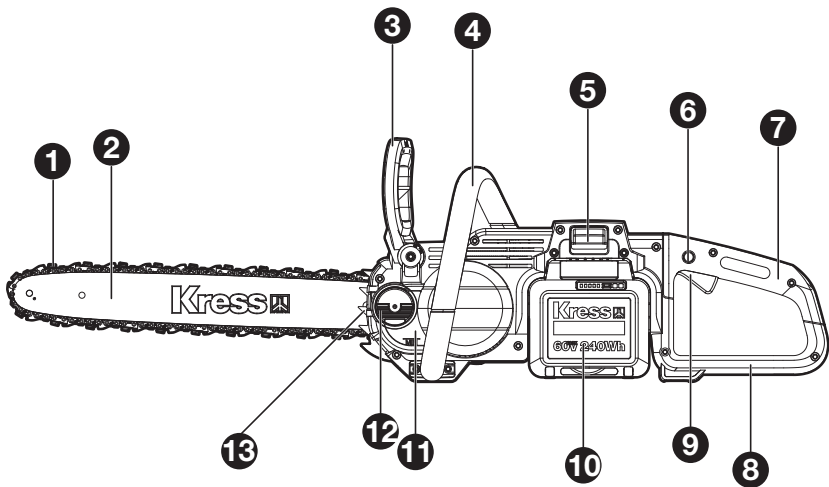

# COMPONENT LIST

1. CHAIN

---

2. GUIDE BAR

---

3. CHAIN BRAKE LEVER (HAND GUARD)

---

4. FRONT HANDLE

---

5. BATTERY PACK RELEASE BUTTON

---

6. LOCK-OFF BUTTON

---

7. REAR HANDLE

---

8. REAR HAND GUARD

---

9. ON/OFF SWITCH

---

10. BATTERY PACK \*

---

11. OIL LEVEL WINDOW

---

12. OIL FILLER CAP

---

13. BUMPER SPIKE

---

14. DRIVE COVER

---

15. HEX NUTS

---

16. CHAIN TENSIONING SCREW

---

17. CHAIN DIRECTION SYMBOL

---

18. OIL OUTLET

---

19. BAR LOCATING STUDS

---

20. BAR PAD

---

21. DRIVE SPROCKET

---

22. PROTECTIVE SCABBARD

---

23. WRENCH (SEE FIG A1)

---

24. CHAIN TENSIONING PIN

---

25. CHAIN TENSIONING HOLE (SEE FIG A2)

---

\* Not all the accessories illustrated or described are included in standard delivery.

# PRODUCT SAFETY

## GENERAL POWER TOOL

### SAFETY WARNINGS

 **WARNING** Read all safety warnings, instructions, illustrations and specifications provided with this power tool. Failure to follow all instructions listed below may result in electric shock, fire and/or serious injury.

Save all warnings and instructions for future reference.

The term “power tool” in the warnings refers to your mains-operated (corded) power tool or battery-operated (cordless) power tool.

#### 1. WORK AREA SAFETY

- a) **Keep work area clean and well lit.** Cluttered or dark areas invite accidents.
- b) **Do not operate power tools in explosive atmospheres, such as in the presence of flammable liquids, gases or dust.** Power tools create sparks which may ignite the dust or fumes.
- c) **Keep children and bystanders away while operating a power tool.** Distractions can cause you to lose control.

#### 2. ELECTRICAL SAFETY

- a) **Power tool plugs must match the outlet.** Never modify the plug in any way. Do not use any adapter plugs with earthed (grounded) power tools. Unmodified plugs and matching outlets will reduce risk of electric shock.
- b) **Avoid body contact with earthed or grounded surfaces, such as pipes, radiators, ranges and refrigerators.** There is an increased risk of electric shock if your body is earthed or grounded.
- c) **Do not operate the machine in rain or wet conditions.** This may increase the risk of electric shock. Once got wet in the rain during operation, the machine and the battery should be dried before storing or charging. Remove the battery and reinsert it if the machine fails to turn on. Keep battery connection free of dirt and debris, and clean with a soft and dry brush or cloth.
- d) **Do not abuse the cord. Never use the cord for carrying, pulling or unplugging the power tool. Keep cord away from heat, oil, sharp edges or moving parts.** Damaged or entangled cords increase the risk of electric shock.
- e) **When operating a power tool outdoors, use an extension cord suitable for outdoor use.** Use of a cord suitable for outdoor use reduces the risk of electric shock.
- f) **If operating a power tool in a damp location is unavoidable, use a residual current device (RCD) protected supply.** Use of an RCD reduces the risk of electric shock.

#### 3. PERSONAL SAFETY

- a) **Stay alert, watch what you are doing and use**

common sense when operating a power tool. Do not use a power tool while you are tired or under the influence of drugs, alcohol or medication. A moment of inattention while operating power tools may result in serious personal injury.

- b) **Use personal protective equipment. Always wear eye protection.** Protective equipment such as dust mask, non-skid safety shoes, hard hat, or hearing protection used for appropriate conditions will reduce personal injuries.
  - c) **Prevent unintentional starting. Ensure the switch is in the off-position before connecting to power source and/or battery pack, picking up or carrying the tool.** Carrying power tools with your finger on the switch or energising power tools that have the switch on invites accidents.
  - d) **Remove any adjusting key or wrench before turning the power tool on.** A wrench or a key left attached to a rotating part of the power tool may result in personal injury.
  - e) **Do not overreach. Keep proper footing and balance at all times.** This enables better control of the power tool in unexpected situations.
  - f) **Dress properly. Do not wear loose clothing or jewellery. Keep your hair, clothing and gloves away from moving parts.** Loose clothes, jewellery or long hair can be caught in moving parts.
  - g) **If devices are provided for the connection of dust extraction and collection facilities, ensure these are connected and properly used.** Use of dust collection can reduce dust-related hazards.
  - h) **Do not let familiarity gained from frequent use of tools allow you to become complacent and ignore tool safety principles.** A careless action can cause severe injury within a fraction of a second.
- #### 4. POWER TOOL USE AND CARE
- a) **Do not force the power tool. Use the correct power tool for your application.** The correct power tool will do the job better and safer at the rate for which it was designed.
  - b) **Do not use the power tool if the switch does not turn it on and off.** Any power tool that cannot be controlled with the switch is dangerous and must be repaired.
  - c) **Disconnect the plug from the power source and/or the battery pack from the power tool before making any adjustments, changing accessories, or storing power tools.** Such preventive safety measures reduce the risk of starting the power tool accidentally.
  - d) **Store idle power tools out of the reach of children and do not allow persons unfamiliar with the power tool or these instructions to operate the power tool.** Power tools are dangerous in the hands of untrained users.
  - e) **Maintain power tools. Check for misalignment or binding of moving parts, breakage of parts and any other condition that may affect the power tool's operation. If damaged, have**

the power tool repaired before use. Many accidents are caused by poorly maintained power tools.

- f) **Keep cutting tools sharp and clean.** Properly maintained cutting tools with sharp cutting edges are less likely to bind and are easier to control.
- g) **Use the power tool, accessories and tool bits etc. in accordance with these instructions, taking into account the working conditions and the work to be performed.** Use of the power tool for operations different from those intended could result in a hazardous situation.
- h) **Keep handles and grasping surfaces dry, clean and free from oil and grease.** Slippery handles and grasping surfaces do not allow for safe handling and control of the tool in unexpected situations.

## 5. BATTERY TOOL USE AND CARE

- a) **Recharge only with the charger specified by the manufacturer.** A charger that is suitable for one type of battery pack may create a risk of fire when used with another battery pack.
- b) **Use power tools only with specifically designated battery packs.** Use of any other battery packs may create a risk of injury and fire.
- c) **When battery pack is not in use, keep it away from other metal objects, like paper clips, coins, keys, nails, screws or other small metal objects, that can make a connection from one terminal to another.** Shorting the battery terminals together may cause burns or a fire.
- d) **Under abusive conditions, liquid may be ejected from the battery; avoid contact. If contact accidentally occurs, flush with water. If liquid contacts eyes, additionally seek medical help.** Liquid ejected from the battery may cause irritation or burns.
- e) **Do not use a battery pack or tool that is damaged or modified.** Damaged or modified batteries may exhibit unpredictable behaviour resulting in fire, explosion or risk of injury.
- f) **Do not expose a battery pack or tool to fire or excessive temperature.** Exposure to fire or temperature above 130 °C may cause explosion.
- g) **Follow all charging instructions and do not charge the battery pack or tool outside the temperature range specified in the instructions.** Charging improperly or at temperatures outside the specified range may damage the battery and increase the risk of fire.

## 6. SERVICE

- a) **Have your power tool serviced by a qualified repair person using only identical replacement parts.** This will ensure that the safety of the power tool is maintained.
- b) **Never service damaged battery packs.** Service of battery packs should only be performed by the manufacturer or authorized service providers.

# 1) GENERAL CHAIN SAW

## SAFETY WARNINGS:

- a) **Keep all parts of the body away from the saw chain when the chain saw is operating. Before you start the chain saw, make sure the saw chain is not contacting anything.** A moment of inattention while operating chain saws may cause entanglement of your clothing or body with the saw chain.
- b) **Always hold the chain saw with your right hand on the rear handle and your left hand on the front handle.** Holding the chain saw with a reversed hand configuration increases the risk of personal injury and should never be done.
- c) **Hold the chain saw by insulated gripping surfaces only, because the saw chain may contact hidden wiring.** Saw chains contacting a "live" wire may make exposed metal parts of the chain saw "live" and could give the operator an electric shock.
- d) **Wear safety glasses protection. Further protective equipment for hearing, head, hands, legs and feet is recommended.** Adequate protective clothing will reduce personal injury by flying debris or accidental contact with the saw chain.
- e) **Do not operate a chain saw, on a ladder, from a rooftop, or any unstable support.** Operation of a chain saw in this manner could result in serious personal injury.
- f) **Always keep proper footing and operate the chain saw only when standing on fixed, secure and level surface.** Slippery or unstable surfaces may cause a loss of balance or control of the chain saw.
- g) **When cutting a limb that is under tension , be alert for spring back.** When the tension in the wood fibres is released , the spring loaded limb may strike the operator and/or throw the chain saw out of control.
- h) **Use extreme caution when cutting brush and saplings.** The slender material may catch the saw chain and be whipped toward you or pull you off balance.
- i) **Carry the chain saw by the front handle with the chain saw switched off and away from your body. When transporting or storing the chain saw , always fit the guide bar cover.** Proper handling of the chain saw will reduce the likelihood of accidental contact with the moving saw chain.
- j) **Follow instructions for lubricating, chain tensioning and changing the bar and chain.** Improperly tensioned or lubricated chain may either break or increase the chance for kickback.
- k) **Cut wood only. Do not use chain saw for purposes not intended. For example: do not use chain saw for cutting metal, plastic, masonry or non-wood building materials.** Use of the chain saw for operations different than intended could result in a hazardous situation.
- l) **Do not attempt to fell a tree until you have an understanding of the risks and how to avoid them.** Serious injury could occur to the operator

or bystanders while felling a tree.

- m) **Follow all instructions when clearing jammed material, storing or servicing the chain saw. Make sure the switch is off and the battery pack is removed.** Unexpected actuation of the chain saw while clearing jammed material or servicing may result in serious personal injury.
- n) **Recommendation that the first-time user should, as a minimum, practice cutting logs on a saw-horse or cradle.**
- o) **Recommendation to have sharpening and maintenance of the saw chain performed by authorised service centers.**

## 2) CAUSES AND OPERATOR PREVENTION OF KICKBACK:

Kickback may occur when the nose or tip of the guide bar touches an object, or when the wood closes in and pinches the saw chain in the cut.

Tip contact in some cases may cause a sudden reverse reaction, kicking the guide bar up and back towards the operator. Pinching the saw chain along the top of the guide bar may push the guide bar rapidly back towards the operator.

Either of these reactions may cause you to lose control of the saw which could result in serious personal injury. Do not rely exclusively upon the safety devices built into your saw. As a chain saw user, you should take several steps to keep your cutting jobs free from accident or injury.

Kickback is the result of chain saw misuse and/or incorrect operating procedures or conditions and can be avoided by taking proper precautions as given below:

- a) **Maintain a firm grip, with thumbs and fingers encircling the chain saw handles, with both hands on the saw and position your body and arm to allow you to resist kickback forces.** Kickback forces can be controlled by the operator, if proper precautions are taken. Do not let go of the chain saw.
- b) **Do not overreach and do not cut above shoulder height.** This helps prevent unintended tip contact and enables better control of the chain saw in unexpected situations.
- c) **Only use replacement bars and chains specified by the manufacturer.** Incorrect replacement guide bars and saw chains may cause chain breakage and/or kickback.
- d) **Follow the manufacturer's sharpening and maintenance instructions for the saw chain.** Decreasing the depth gauge height can lead to increased kickback.

## SAFETY WARNINGS FOR

## BATTERY PACK

- a) Do not dismantle, open or shred cells or battery pack.
- b) Do not short-circuit a battery pack. Do not store battery packs haphazardly in a box or drawer where they may short-circuit each other or be short-circuited by conductive materials. When battery pack is not in use, keep it away from other metal objects, like paper clips, coins, keys, nails, screws or other small metal objects, that can make a connection from one terminal to another. Shorting the battery terminals together may cause burns or a fire.
- c) Do not expose battery pack to heat or fire. Avoid storage in direct sunlight.
- d) Do not subject battery pack to mechanical shock.
- e) In the event of battery leaking, do not allow the liquid to come into contact with the skin or eyes. If contact has been made, wash the affected area with copious amounts of water and seek medical advice.
- f) Keep battery pack clean and dry.
- g) Wipe the battery pack terminals with a clean dry cloth if they become dirty.
- h) Battery pack needs to be charged before use. Always refer to this instruction and use the correct charging procedure.
- i) Do not maintain battery pack on charge when not in use.
- j) After extended periods of storage, it may be necessary to charge and discharge the battery pack several times to obtain maximum performance.
- k) Recharge only with the charger specified by Kress. Do not use any charger other than that specifically provided for use with the equipment.
- l) Do not use any battery pack which is not designed for use with the equipment.
- m) Keep battery pack out of the reach of children.
- n) Retain the original product literature for future reference.
- o) Remove the battery from the equipment when not in use.
- p) Dispose of properly.
- q) Do not use battery packs of different manufacture, size or type.
- r) Keep the battery away from microwaves and high pressure.
- s) **Warning!** Do not use non-rechargeable batteries.

## USER MANUAL REQUIREMENTS FOR WIRELESS PRODUCT

- a) Operation of this device is subject to the following two conditions:
  - (1) This device may not cause harmful interfer-

ence, and

(2) this device must accept any interference received, including interference that may cause undesired operation.

- b) Caution: Changes or modifications to this unit not expressly approved by the party responsible for compliance could void the user's authority to operate the equipment.
- c) NOTE: This equipment generates, uses and can radiate radio frequency energy and, if not installed and used in accordance with the instructions, may cause harmful interference to radio communications. However, there is no guarantee that interference will not occur in a particular installation. If this equipment does cause harmful interference to radio or television reception, which can be determined by turning the equipment off and on, the user is encouraged to try to correct the interference by one or more of the following measures:
  - Reorient or relocate the receiving antenna.
  - Increase the separation between the equipment and receiver.
  - Connect the equipment into an outlet on a circuit different from that to which the receiver is connected.
  - Consult the dealer or an experienced radio/TV technician for help

## SAVE THESE INSTRUCTIONS

### Instructions concerning the proper techniques for basic felling, limbing, and cross-cutting (bucking)

#### 1. Felling a tree

When bucking and felling operations are being performed by two or more persons at the same time, the felling operations should be separated from the bucking operation by a distance of at least twice the height of the tree being felled. Trees should not be felled in a manner that would endanger any person, strike any utility line or cause any property damage. If the tree does make contact with any utility line, the company should be notified immediately.

The Chainsaw operator should keep on the uphill side of the terrain as the tree is likely to roll or slide downhill after it is felled.

An escape path should be planned and cleared as necessary before cuts are started. The escape path should extend back and diagonally to the rear of the expected line of fall as illustrated in Figure 1. Before felling is started, consider the natural lean of the tree, the location of larger branches and the wind direction to judge which way the tree will fall. Remove dirt, stones, loose bark, nails, staples and wire from the tree.

#### 2. Notching undercut

Make the notch 1/3 the diameter of the tree, perpendicular to the direction of falls as illustrated in Figure 1. Make the lower horizontal notching cut (W) first. This will help to avoid pinching either the saw chain or the guide bar when the second notch (X) is being made.

#### 3. Felling back cut

Make the felling back cut (Y) at least 50 mm higher than the horizontal notching cut as illustrated in Figure 1.

Keep the felling back cut parallel to the horizontal notching cut.

Make the felling back cut so enough wood is left to act as a hinge. The hinge wood keeps the tree from twisting and falling in the wrong direction. Do not cut through the hinge.

As the felling gets close to the hinge, the tree should begin to fall. If there is any chance that the tree may not fall in desired direction or it may rock back and bind the saw chain, stop cutting before the felling back cut is complete and use wedges of wood, plastic or aluminium (Z) to open the cut and drop the tree along the desired line of fall (3).

When the tree begins to fall remove the Chainsaw from the cut, stop the motor, put the Chainsaw down, then use the retreat path planned (2). Be alert for overhead limbs falling and watch your footing. (See Figure 1)

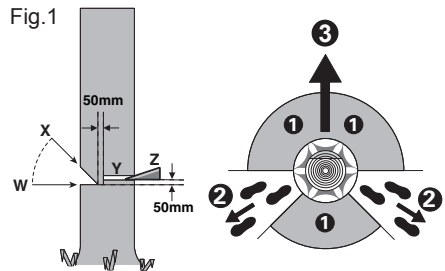

#### 4. Limbing a tree

Limbing is removing the branches from a fallen tree.

When limbing leave larger lower limbs to support the log off the ground. Remove the small limbs in one cut as illustrated in Figure 2. Branches under tension should be cut from the bottom up to avoid binding the Chainsaw.

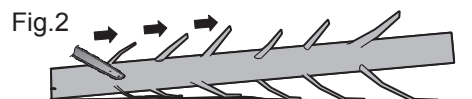

## 5. Bucking a log

Bucking is cutting a log into lengths. It is important to make sure your footing is firm and your weight is evenly distributed on both feet. When possible, the log should be raised and supported by the use of limbs, logs or chocks. Follow the simple directions for easy cutting.

When the log is supported along its entire length as illustrated in Figure 3, it is cut from the top (overbuck), avoid contacting ground as this will greatly reduce the chain sharpness.

Fig.3

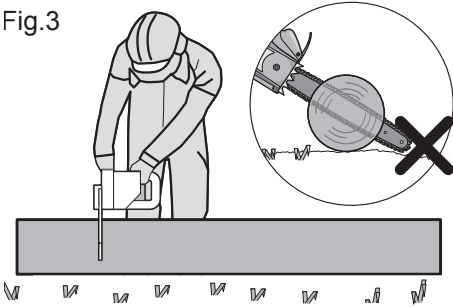

When the log is supported on one end, as illustrated in Figure 4, cut 1/3 the diameter from the underside (underbuck) (1). Then make the finished cut by overbucking (2) to meet the first cut.

Fig.4

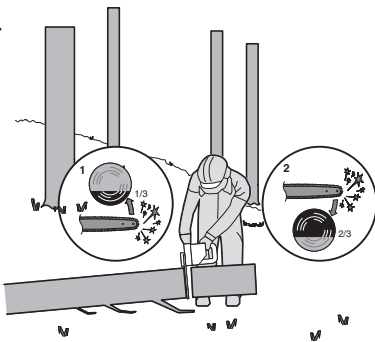

When the log is supported on both ends, as illustrated in Figure 5, cut 1/3 the diameter from the top (overbuck) (1). Then make the finished cut by underbucking (2) the lower 2/3 to meet the first cut.

Fig.5

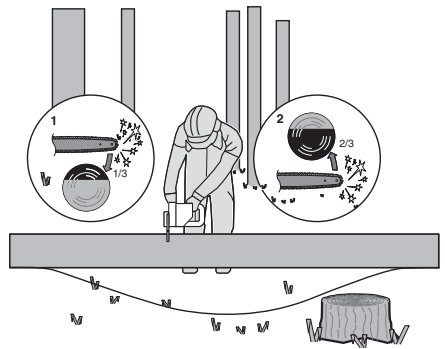





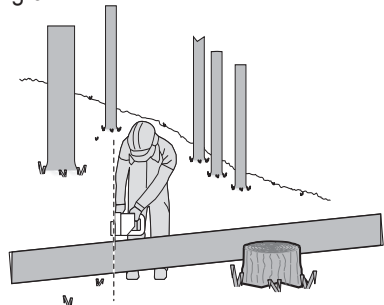

When bucking on a slope always stand on the uphill side of the log, as illustrated in Figure 6. When “cutting through”, to maintain complete control release the cutting pressure near the end of the cut without relaxing your grip on the Chainsaw handles. Don't let the chain contact the ground. After completing the cut, wait for the saw chain to stop before you move the Chainsaw. Always stop the motor before moving from tree to tree.

Fig.6



# SYMBOLS

	To reduce the risk of injury, user must read instruction manual
	WARNING
	Wear ear protection
	Wear eye protection
	Wear dust mask
	Always use chain saw two-handed
	Beware of chain saw kickback and avoid contact with bar tip
	Wear head protection
	Wear protective gloves
 <b>Li-Ion</b>  <b>Li-Ion</b>	Li-Ion battery. This product has been marked with a symbol relating to 'separate collection' for all battery packs and battery pack. It will then be recycled or dismantled in order to reduce the impact on the environment. Battery packs can be hazardous for the environment and for human health since they contain hazardous substances.
	Do not burn
	Batteries may enter water cycle if disposed improperly, which can be hazardous for ecosystem. Do not dispose of waste batteries as unsorted municipal waste.
	Unlock

	Lock
	RCM marking

**ABN:** Australian Business Number. By this number, business information such as entity type, status, business location etc. can be found at website <http://abr.business.gov.au>.  
 ABN of Positec Australia Pty Limited is 14 101 682 357

# ASSEMBLY & OPERATION

 **NOTE:** Before using the tool, read the instruction book carefully.

## ASSEMBLY

 **WARNING!** Do not install the battery pack before it has been completely assembled. Always use gloves when handling the chain.

### CHAIN AND GUIDE BAR ASSEMBLY

1. Unpack all parts carefully. Remove the drive cover by turning the hex nuts in a counter-clockwise direction. (See Fig. A1)

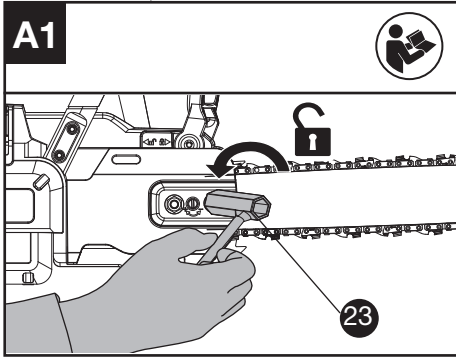

2. Place the Chainsaw on a solid, level surface.
3. Use only genuine Kress chains or those recommended for the Guide Bar.
4. Slide the chain in the slot around the guide bar. Ensure the chain is in correct running direction by comparing it to the chain icon, or referring to the chain direction symbol found on the saw body.
5. Fit the chain onto the drive sprocket, so that the two bar locating studs on the bar pad fit into the keyway of the opening on the guide bar. Ensure that the chain tension hole fits on the chain tension pin. (See Fig. A2).

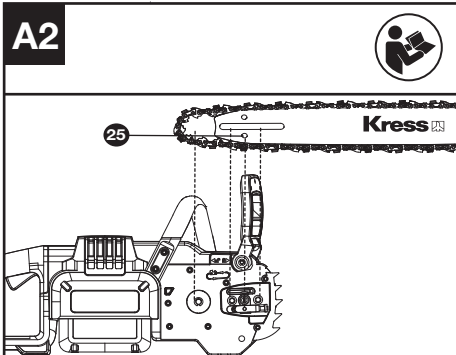

6. Assure all parts are seated properly and hold chain and guide bar in a level position. Make sure

the drive links are fully seated in the drive sprocket (See Fig. A3), avoiding a kink as shown in Fig. A4. If kink occurs, pick up on the chain at the guide bar just ahead of the kink and then pull the kink out.

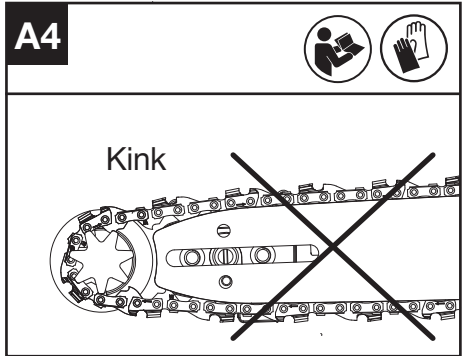
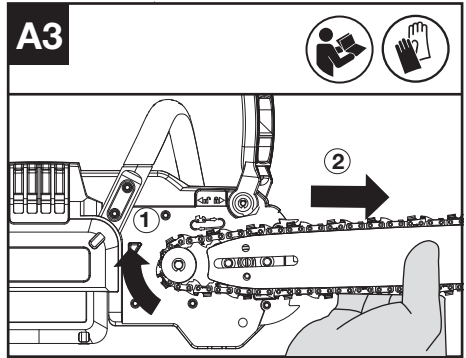

**NOTE:** Chain should rotate freely and be free of kinks.

7. Fit the drive cover and tighten the drive cover by turning the hex nuts clockwise until it is slightly tight. (See Fig. A5)

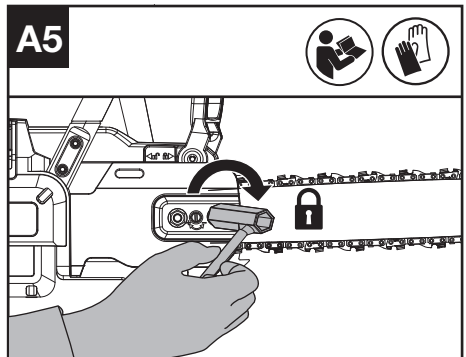

 **WARNING:** The chain is not yet tensioned. Tensioning the chain applies as described

under “TENSIONING CHAIN”. The chain now needs to be inspected to make sure it is properly tensioned.

## TENSIONING CHAIN (See Fig. B, C)

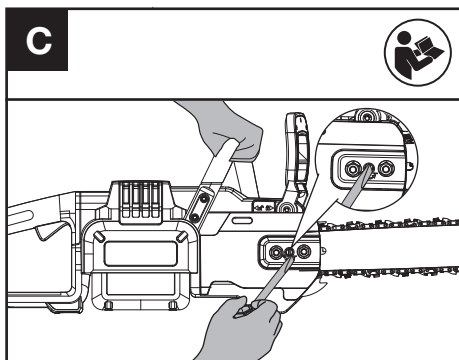
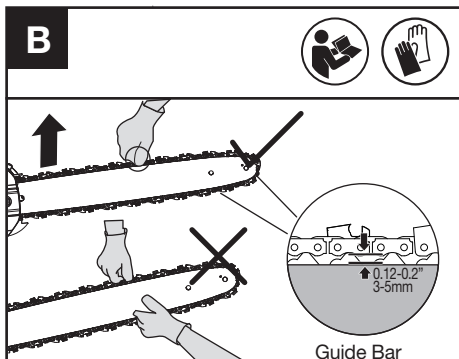

1. Loosen the nuts on the guide cover with wrench as shown in Fig A1. But remember not to remove the cover.
2. Lift the chain cover of guide bar and turn the tensioning screw with a wrench in a clockwise direction. Tighten the tensioning screw until the chain is tensioned correctly and can still move easily. (See Fig B&C)
3. Tighten the nuts on the drive cover with wrench as shown in A5 until it is tight.
4. Double check the tension set by the chain tensioning screw. The correct chain tension is reached when the chain can be raised approx. Half the driveline depth from the guide bar in the center. This should be done by using one hand to raise the chain against the weight of the machine.

**NOTE:** The chain will stretch while cutting and lose proper tension. When the chain becomes loose, completely unscrew the hex nuts or turn the hex nuts around three full turns in a counter-clockwise direction, then re-tension the chain and tighten the hex nuts to properly reset the chain tension by repeating Steps 1-4 listed above.

## **WARNING:**

- Removing the battery pack before adjusting saw chain tension.
  - Cutting edges on chain are sharp. Use protective gloves when handling chain.
  - Maintain proper chain tension always. A loose chain will increase the risk of kickback. A loose chain may jump out of guide bar groove. This may injure operator and damage chain. A loose chain will cause chain, bar, and sprocket to wear rapidly.
- NOTE:** The chain is properly tensioned when it can be lifted off of the Guide Bar and the driveline is within the rail of the Guide Bar.

## LUBRICATION (See Fig. D)

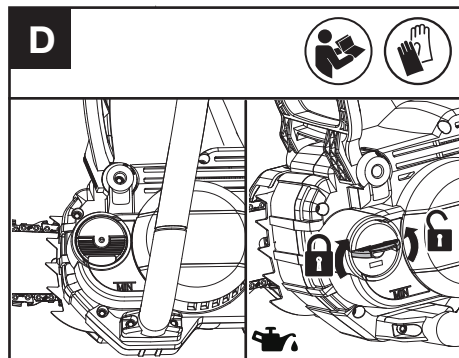

-  IMPORTANT:** The Chainsaw is not filled with oil. It is essential to fill with oil before use.
- Never operate the Chainsaw without bar and chain oil or allow the tank to become empty, as this will result in extensive damage to the product.
- NOTE:** Chain life and cutting capacity depend on optimum lubrication. Therefore, the chain is automatically oiled during operation.

## FILLING OIL TANK:

### **WARNING:** Removing the battery pack before filling the oil tank.

1. Set Chainsaw on any suitable surface with oil filler cap facing upward.
2. Clean area around the oil filler cap with cloth and unscrew the cap by turning it counter clockwise.
3. Add bar and chain oil until tank is full.
4. Avoid dirt or debris entering oil tank, refill oil filler cap and tighten by turning clockwise until hand tight.

** It is important to use bar and chain lubricant (not automotive oil) that is formulated to perform over a wide temperature range with no dilution required. This can be found at the location where you purchased this saw or your local hardware store. Do not use dirty, used or otherwise contaminated oils. Damage may**

occur to the bar or chain. Use of non approved oil will void the warranty.

Do not swallow any type of bar oil. If swallowed, call a physician immediately. Keep out of reach of children. Store away from heat or open flame.

### CHECKING THE AUTOMATIC OILER

Proper functioning of the automatic oiler can be checked by running the Chainsaw and pointing the tip of the guide chain bar towards a piece of cardboard or paper on the ground. If an increasing oil pattern develops on the cardboard, the automatic oiler is operating fine. If there is no oil pattern, despite a full oil reservoir, contact Kress customer service agent or Kress approved service agent.

**NOTE:** It make take an extended period of time (1 minute +) for the pump to prime when new or after the saw has not been in use for an extended period of time.

**CAUTION:** Do not touch the ground with the chain. Ensure safety clearance of 6" (15 cm).

### BEFORE OPERATION TESTING THE CHAINSAW AND BATTERY

#### Checking the controls

##### Throttle Lock-Out Button and Throttle Trigger

1. Remove the battery.
2. Try to press the Throttle Trigger. If the Throttle Trigger can be pressed, the Throttle Lock-Out Button is defective. Stop using the chainsaw and contact the service agent.
4. Hold and press the Throttle Lock-Out Button first, then press the Throttle Trigger.
5. Release the Throttle Trigger and the Throttle Lock-Out Button. If the Throttle Trigger or the Throttle Lock-Out Button is get stuck and cannot spring back to its original position. Stop using the chainsaw and contact the service agent.

## OPERATION

### BEFORE USING YOUR CORDLESS TOOL

**WARNING!** The charger and battery pack are specially designed to work together so do not attempt to use any other devices. Never insert or allow metallic objects into your charger or battery pack connections because of an electrical failure and hazard will occur.

**NOTE:** Your battery pack is UNCHARGED and you must charge once before use. The battery charger supplied is matched to the Li-ion battery installed in the machine. Do not use another battery charger.

### CHECKING THE BATTERY CHARGE CONDITION (See Fig. E1)

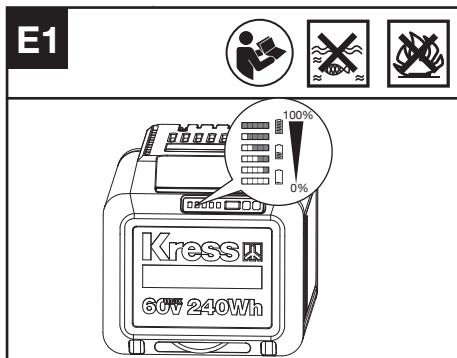

Before starting or after use, press the power test button on the battery pack to check the battery capacity.

Note: Fig E1 only applies for the battery pack with battery indicator light.

Remarks	LED light	Battery condition
Five green lights are illuminated.		80% ≤ Power level ≤ 100%
Four green lights are illuminated.		60% ≤ Power level < 80%
Three green lights are illuminated.		40% ≤ Power level < 60%
Two green lights are illuminated.		20% ≤ Power level < 40%
One green light is illuminated.		10% ≤ Power level < 20%
One green light is flashing.		0% ≤ Power level < 10%

## CHARGING YOUR BATTERY PACK (See Fig. E2)

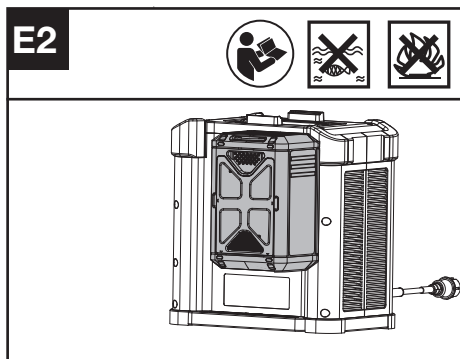

The Li-ion battery is protected against deep discharging. When the battery is empty, the machine is switched off by means of a protective circuit. Each battery must be fully charged before the first use.

## TO REMOVE OR INSTALL BATTERY PACK (See Fig. F, G)

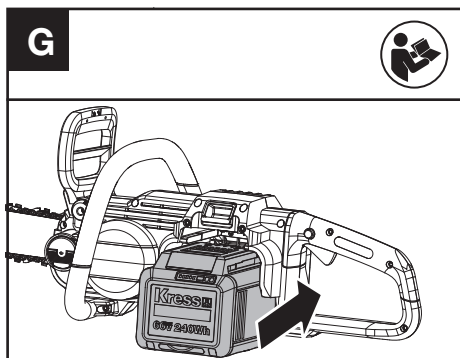
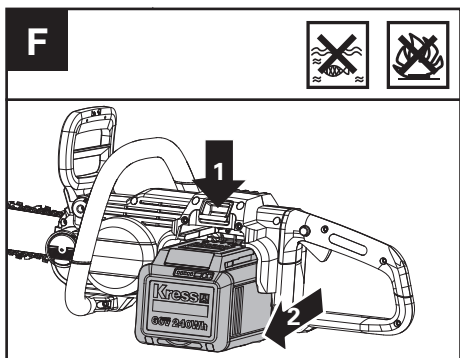

Depress the battery pack release button to remove the battery pack from your tool. After recharging,

insert the battery pack into the battery port. A simple push and slight pressure will be sufficient until a click is heard. Check to see if the battery is fully secured. **NOTE:** When removing the battery pack, hold it firmly to avoid dropping and injury.

## SWITCHING ON AND OFF (SEE FIG. H)

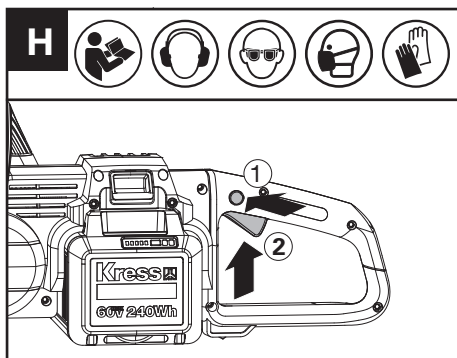

**ATTENTION:** Check the battery packs before using your cordless tool. Only use the battery pack listed in the accessories section.

To switch on the tool, press the throttle lock-out button, then fully press the throttle trigger and hold in this position. The throttle lock-out button can now be released. If the saw does not function, please see CHAIN BRAKE LEVER information below. For switching off, release the throttle trigger.

**NOTE:** The chain brake must be deactivate in order for the saw to be switched on.

## CHAIN BRAKE LEVER (See Fig. I)

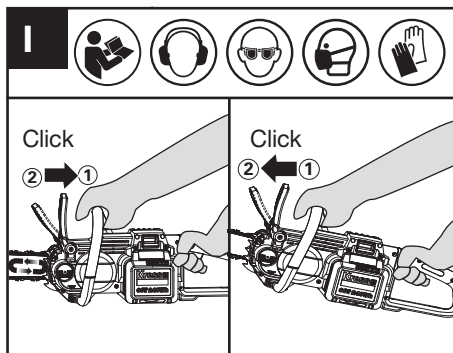

The chain brake lever is a safety mechanism activated through the front hand guard, when kickback occurs. Chain stops immediately.

The following function check should be carried out at regular intervals. Pull the front hand guard towards the operator (position ①) to deactivate chain brake. To activate the chain brake, push front hand guard forwards (position ②)\*.

## NOTE:

1. If the saw is unable to start, even though it is assembled properly and working with fully charged battery packs, then you should check if the chain brake lever is in the correct position (position ①).
2. \*When the chain brake is activated, the saw chain should stop instantly. If the saw chain does not stop or take time to slow down, please stop using the chain saw and contact the service agent.

## CUTTING

**⚠ IMPORTANT: Is the oil tank filled? Check the Oil Level Window prior to starting and regularly during operation (See Fig. J). Refill oil when oil level is low. A full oil tank will last approx. 12 minutes of cutting depending on sawing intensity and stops.**

**Check recent replaced chain tension about every 10 minutes during operation.**

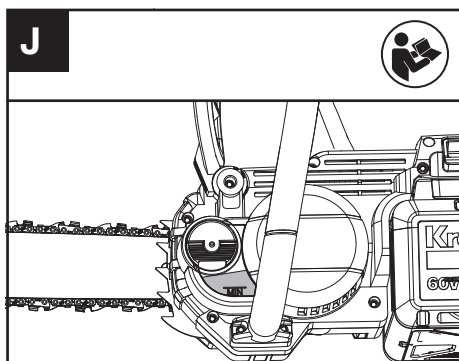

- (1) Installing the battery pack into the machine.
- (2) Make sure section of log to be cut is not laying on the ground. If the log you are cutting is laying on the ground, do not cut completely through and allow the chain to make contact with the soil. Reposition the log for the final separating cut.
- (3) Use both hands to grip saw. Always use left hand to grip front handle and right hand to grip rear handle. Use a firm grip. Thumbs and fingers must wrap around saw handles. (See Fig. K)

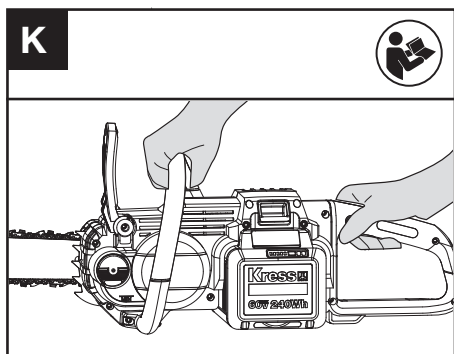

- (4) Make sure your footing is firm. Keep feet-shoulder wide apart. Distribute your weight evenly on both feet.
- (5) When ready to make a cut, push the throttle lock-out button completely in with the right thumb and squeeze the trigger. This will turn saw on. Releasing the trigger will turn the saw off. Make sure the saw is running at full speed before starting a cut.
- (6) When starting a cut, slowly place moving chain against the wood. The wood should be as close to the saw body as possible. Hold saw firmly in place to avoid possible bouncing or skating (sideways movement) of the saw.
- (7) Guide the saw using light pressure with your left forearm and do not put excessive force on the saw, letting the saw do its work. The motor will overload and can burn out. It will do the job better and safer at the rate for which it was intended.
- (8) Remove the saw from a cut with the saw running at full speed. Stop the saw by releasing the throttle trigger. Make sure the chain has stopped before setting the saw down.
- (9) Keep practicing on scrap logs in a secure working area until you are comfortable, using a fluid motion and a steady cutting rate.

## KICKBACK SAFETY DEVICES ON THIS SAW

This saw has a low-kickback chain and reduced kickback Guide Bar. Both items reduce the chance of kickback. However, kickback can still occur with this saw.

The following steps will reduce the risk of kickback.

- Use both hands to grip saw while saw is running. Use firm grip. Thumbs and fingers must wrap around saw handles.
- Keep all safety items in place on saw. Make sure they work properly.
- Do not overreach or cut above shoulder height.
- Keep solid footing and balance at all times.
- Stand slightly to the left side of saw. This keeps your body from being in direct line with chain.
- Do not let Guide Bar nose tip touch anything when chain is moving.
- Never try cutting through two logs at same time. Only cut one log at a time.
- Do not bury the Guide Bar nose or try plunge cut (boring into wood using guide bar nose). This type of cutting is for properly trained professionals only.
- Watch for shifting of wood or other forces that may pinch chain.
- Use extreme caution when reentering a previous cut.
- Use only the low-kickback chain and guide bar that were supplied with this Chainsaw or or are recommended as a replacement.
- Never use a dull or loose chain. Keep chain sharp with proper tension.

## HOW TO USE SAW SAFELY

1. Use the Chainsaw only with secure footing.
2. Hold the Chainsaw at the right-hand side of your

body (See Fig. L).

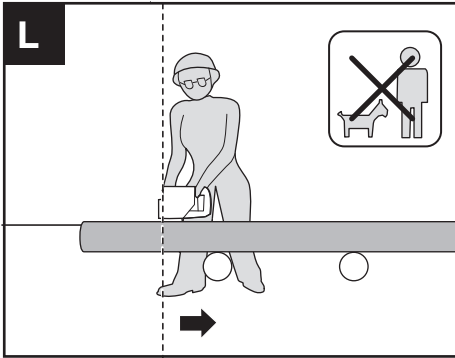

3. The chain must be running at full speed before it makes contact with the wood.
4. Use the bumper spikes to secure the saw onto the wood when starting to cut.
5. Use the Bumper Spikes as a leverage point while cutting if necessary. (See Fig. M)

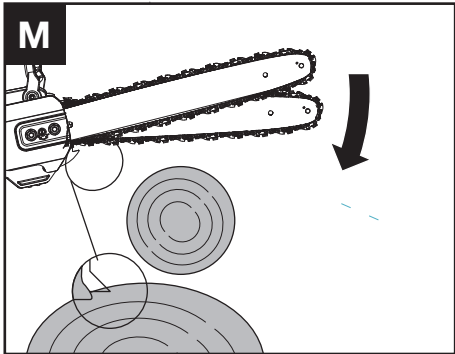

6. Do not operate the Chainsaw with arms fully extended, attempt to saw areas which are difficult to reach, or stand on a ladder while sawing (See Fig. N).

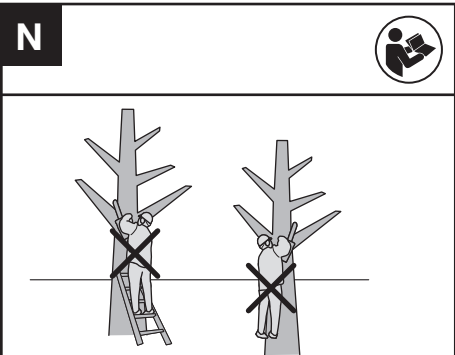

Never use the Chainsaw above shoulder height.

## CUTTING WOOD UNDER TENSION (SEE FIG. O)

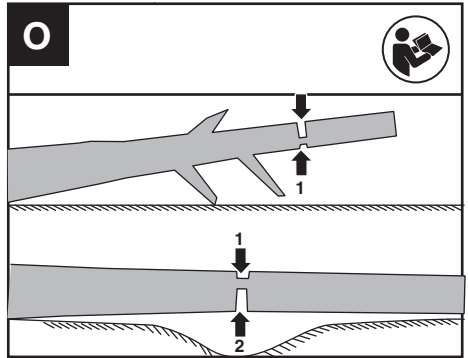

**WARNING:** When cutting a limb that is under tension, use extreme caution. Be alert for wood springing back. When wood tension is released, limb could spring back and strike operator causing severe injury or death.

When sawing logs supported on both ends, start the cut from above (1) about 1/3 of the diameter into the log (overbuck) and then finish the cut (2) from below, in order to avoid contact of the Chainsaw with the ground. When sawing logs supported on only one end, start the cut from below (1) about 1/3 of the diameter into the log (underbuck) and finish the cut from above (2) in order to avoid log splitting or jamming of the Chainsaw.

When cutting short sections (example of firewood), it is not normally necessary to perform the underbuck cut when the log is supported on one end.

### For Battery tools

The recommended ambient temperature range for discharging is  $-20^{\circ}\text{C}$   $-45^{\circ}\text{C}$  ( $-4^{\circ}\text{F}$   $-113^{\circ}\text{F}$ ).

The recommended ambient temperature range for the charging system during charging is  $-5^{\circ}\text{C}$   $-45^{\circ}\text{C}$  ( $23^{\circ}\text{F}$   $-113^{\circ}\text{F}$ ).

### Low temperature use reminder :

To guarantee optimal performance and maintain the longevity of your battery system, please ensure that the battery is at normal room temperature before starting work in cold conditions.

## TRANSPORTATION

### Transporting the chainsaw

1. Switch off the chainsaw and remove the battery.
2. When transporting your chainsaw by hand, hold the front handle of chain saw to make sure that your machine is parallel to the ground.
3. When transporting your chainsaw in a vehicle, secure and position it to prevent movement or damage.

## Transporting the battery

1. Ensure the battery is in a safe condition.
2. Use non-conductive packaging when transporting the battery.
3. The contained Li-Ion batteries are subject to the dangerous goods legislation requirements. Transport batteries only when the battery housing is undamaged. Pack up the batteries in such a manner that cannot move around in the packaging.

## SAW MAINTENANCE

Follow maintenance instructions in this manual. Proper cleaning of saw and chain and guide bar maintenance can reduce chances of kickback. Inspect and maintain saw after each use. This will increase the service life of your saw. Once got wet in the rain during operation, the machine and the battery pack should be dried before storing or charging.

**NOTE:** Even with proper sharpening, risk of kickback can increase with each sharpening.

## MAINTENANCE AND STORAGE OF CHAINSAW

### 1. Remove the battery pack

- When not in use
- Before moving from one place to another
- Before servicing
- Before changing accessories or attachments, such as saw chain and guard

### 2. Inspect Chainsaw before and after each use.

Check saw closely if guard or other part has been damaged. Check for any damage that may affect operator safety or operation of saw. Check for alignment or binding of moving parts. Check for broken or damaged parts. Do not use Chainsaw if damage affects safety or operation. Have damage repaired by authorized service center.

### 3. Maintain Chainsaw with care.

- Keep chain sharp, clean, and lubricated for better and safer performance.
- Follow steps outlined in this manual to sharpen chain.
- Keep handles dry, clean, and free of oil and grease.
- Keep all screws and nuts tight.

### 4. When servicing, use only identical replacement parts.

### 5. When not in use, always store Chainsaw

- in a high or locked place, out of children's reach
- in a dry place
- with protective scabbard in place

## BAR MAINTENANCE

To maximize bar life, the following bar maintenance is recommended.

The bar rails that carry the chain should be cleaned before storing the tool or if the bar or chain appear to be dirty.

The rails should be cleaned every time the chain is removed.

## TO CLEAN THE BAR RAILS:

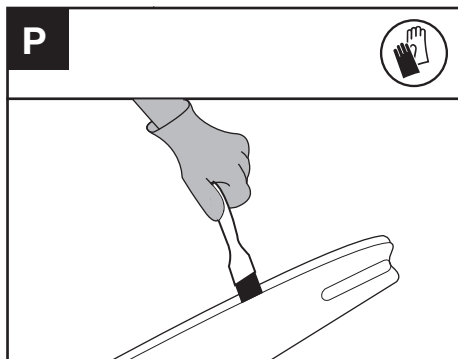

1. Remove drive cover and bar and chain. (see section ASSEMBLY)
2. Using a wire brush, screwdriver or similar tool, clear the residue from the inner groove of the bar. (See Fig. P)
3. Make sure to clean oil passages thoroughly.

## CONDITIONS WHICH REQUIRE CHAIN AND GUIDE BAR MAINTENANCE:

- Saw cuts to one side or at an angle.
- Saw has to be forced through the cut.
- Inadequate supply of oil to the bar and chain.

Check the condition of the guide bar each time the chain is sharpened. A worn guide bar will damage the chain and make cutting difficult.

After each use, remove the battery pack, clean all sawdust from the guide bar and sprocket hole. When rail top is uneven, use a flat file to restore square edges by removing any burrs from the side or top of the bar.

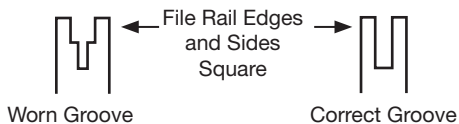

Replace the guide bar when the groove is worn, the guide bar is bent or cracked, or when excess heating or burring of the rails occurs. If replacement is necessary, use only the guide bar specified for your saw in the repair parts list or on the decal located on the Chainsaw.

## REPLACING BAR & CHAIN

Replace chain when cutters are too worn to sharpen or when the chain becomes inoperable. Only use replacement chain noted in this manual. Inspect guide bar before sharpening chain. A worn or damaged guide bar is unsafe. A worn or damaged

guide bar will damage chain. It will also make cutting harder.

## LUBRICATE SPROCKET

**WARNING:** Wear heavy duty gloves when performing any maintenance or service to this tool. Always remove the battery pack before performing any service or maintenance on this tool.

**NOTE:** It is not necessary to remove the chain or bar when lubricating the guide bar sprocket.

1. Clean the bar and sprocket
2. Using a grease gun, insert the tip of the gun into the lubrication hole and inject grease until it appears at the outside edge of the sprocket tip. (See Fig. Q)

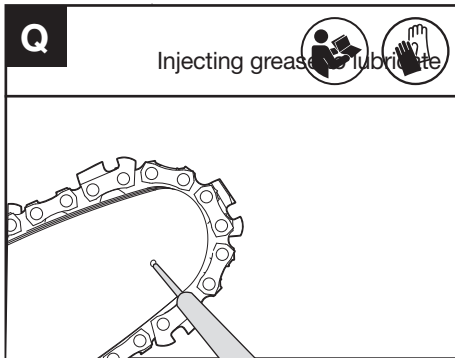

3. To rotate the sprocket pull the chain by hand until the ungreased side of the sprocket is in line with the grease hole. Repeat the lubrication procedure.

## SHARPENING SAW CHAIN

**WARNING:** Remove the battery pack before servicing. Severe injury or death could occur from electrical shock or body contact with moving chain.

Cutting edges on chain are sharp. Use protective gloves when handling chain.

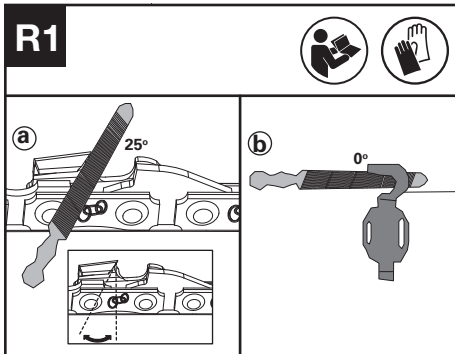

a: Filing angle; b: file position.

Keep chain sharp. Your saw will cut faster and more

safely. A dull chain will cause undue sprocket, Guide Bar, chain, and motor wear. If you must force chain into wood and cutting creates only sawdust with few large chips, chain is dull.

1. Before sharpening, please pay attention of the following steps:( See Fig R1)

How to sharpen the cutters

1. Prepare a round file to sharpen the cutters.(See Fig R2).Note:Firmly clamp the guide bar in a vice before sharpening the chain. Ensure that the chain is not "nipped" and can freely move on the guide bar. Check that the chain is properly tensioned. (See "Tensioning Chain" section).

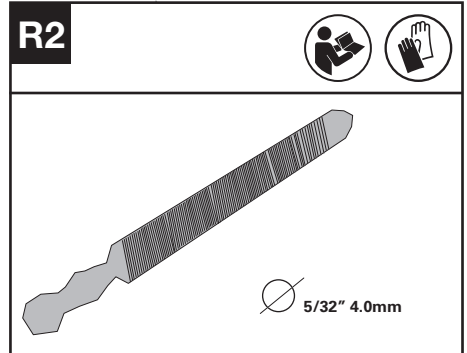

2. Sharpen the cutters with file from the inner side of cutting teeth towards the outside of the chain. (See Fig R3)

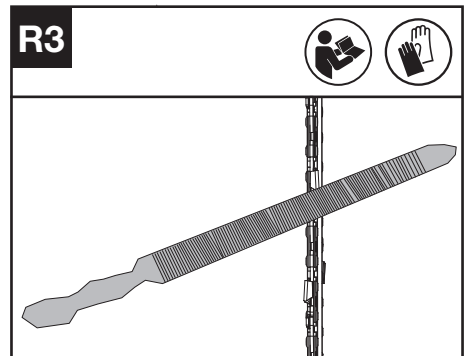

3. File all the cutters on one side of the guide bar.
4. Turn the chainsaw around and file all of the cutters on the opposite side.
5. Ensure that the length of all cutting teeth is same. To ensure efficient, safe and smooth cutting, file the depth gauge height to 0.65mm (0.025"). Make sure that the leading edge of the depth gauge is rounded off. (See Fig R4)

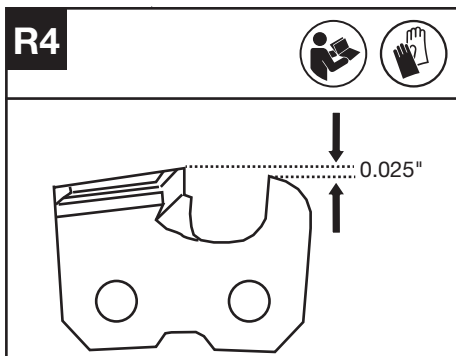

- Once got wet in the rain during operation, the machine and the battery should be dried before storing or charging. Remove the battery and reinsert it if the machine fails to turn on.

### WARNING

It is suggested not to use the chain saw with battery harness for your safety.

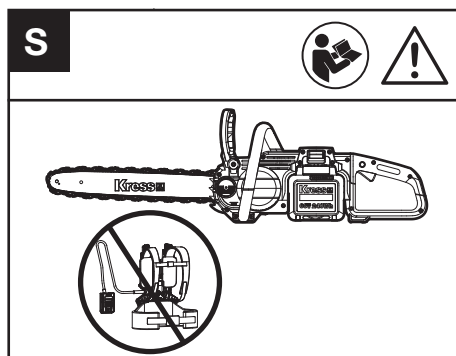

## CLEANING

- Switch off the chainsaw and remove the battery.
- Do not use aggressive detergents or solvents. Clean the machine after use with a damp cloth dipped in mild detergent.
- Keep battery connection free of dirt and debris, and clean with a soft and dry brush or cloth.
- Do not spray water onto the motor and electrical components.
- Do not use pressure washer to clean your machine.

## STORAGE

- Remove the battery pack from the chainsaw before storage.
- Store the chainsaw and the battery in a dry and secure place that is inaccessible to children and other unauthorized people. Remove the cutting attachment if no use for a long time.
- Store the battery only within a temperature range between 5°C (41 °F) and 25°C (77 °F). As an example, do not leave the battery in the car in summer time.

# TROUBLESHOOTING TABLE

The following table gives checks and actions that you can perform if your machine does not operate correctly. If these do not identify/remedy the problem, contact your service agent.



**WARNING: Switch off and remove plug from power source before investigating fault.**

Symptom	Possible Cause	Remedy
Chainsaw fails to operate	Low battery charge. Chain brake not in the proper position.	Charge both the battery packs. Check to see if the chain brake is in position ①. Refer to CHAIN BRAKE for details.
Chainsaw operates intermittently	Applying too much pressure while cutting. Not operating saw at full speed. Over heating  Loose connection. Internal wiring defective. Throttle trigger defective.	Applying relatively less pressure while cutting.  Place the machine in a cool, ventilated place to cool it down. Contact service agent. Contact service agent. Contact service agent.
Dry chain	No oil in reservoir. Oil passage clogged.	Refill oil. Clean oil passage outlet.
Kickback Brake/Run Down Brake	Brake does not stop chain	Contact service agent.
Chain/chain bar overheats.	No oil in reservoir. Oil passage clogged. Chain is over tensioned. Dull chain.	Refill oil. Clean oil passage outlet. Adjust chain tension. Sharpen chain or replace.
Chainsaw rips, vibrates, does not saw properly.	Dull chain. Chain worn out. Chain teeth are facing in the wrong direction. Chain tension too loose.	Sharpen chain or replace. Replace chain. Reassemble with chain in correct direction. Adjust chain tension.

## BATTERY

Problems	Possible Causes	Corrective Action
Error LED lit	The battery is discharged	Charge the battery. If battery fails to charge, contact your Service Agent.
	Temperature issue.	Use the battery in surroundings where temperatures are between -20°C and 45°C(-4°F~113°F) .
	Others	Contact your Service Agent.

# TECHNICAL DATA

Type Designation **KC300 KC300.X (3 - designation of machinery, representative of Chainsaw)**

	<b>KC300 KC300.X**</b>
Rated voltage	60 V  Max. ***
Bar length	40 cm
Chain speed	24 m/s
Oil tank capacity	190 ml
Chain pitch	0.325" LP
Degree of protection	IPX4
Machine weight( without battery, or bar & chain)	3.7kg

\*\* X=1-999,A-Z,M1-M9 they are only used for different customers, there are no safety relevant changes between these models.

\*\*\* Voltage measured without workload. Initial battery voltage reaches maximum of 60 volts. Nominal voltage is 54 volts.

## SUGGESTED BATTERIES AND CHARGERS

<b>Battery</b>	<b>Amp</b>	<b>Charger</b>	<b>Amperage</b>
KAC804	4 Ah	KAC840	30 A

We recommend that you purchase your accessories from the same Dealer that sold you the tool. Refer to the accessory packaging for further details. Your Dealer can assist you and offer advice.

## COMBINATIONS OF CUTTING ATTACHMENTS

<b>Cutting attachment</b>
KAC331-16" Guide Bar
KAC301-16" 0.325" LP Saw Chain
KAC330-14" Guide Bar
KAC300-14" 0.325" LP Saw Chain

## TECHNICAL DATA FOR BATTERY PACK (OPTIONAL)

Frequency bands for Bluetooth	2400-2483.5 MHz
Maximum Transmitted Power for Bluetooth	8 dBm

**Positec Australia Pty Limited**  
10 Corporate Blvd Bayswater , VIC 3153, Australia





Copyright © 2023, Positec. All Rights Reserved.  
AR01723000